

IRIS 80

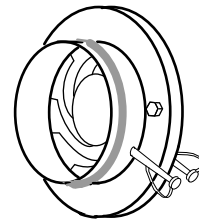

IRIS 100...800

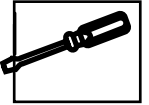
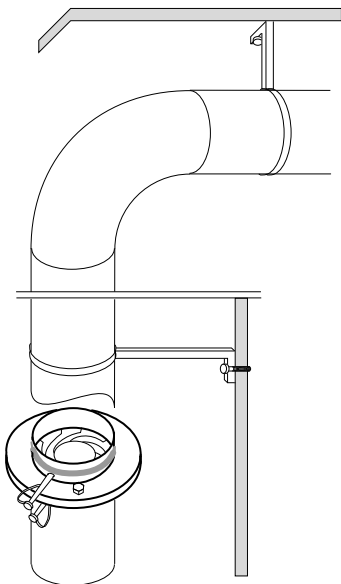
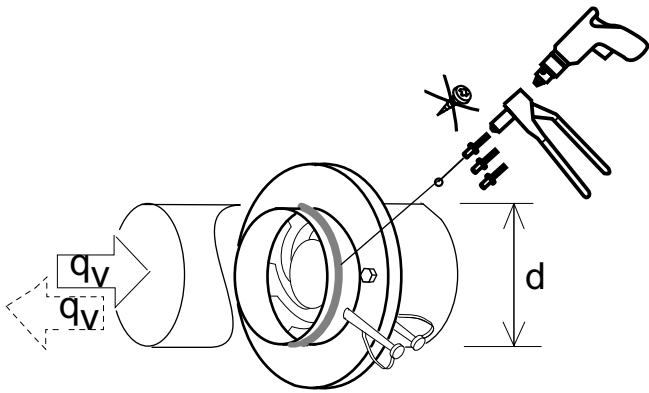

	$L_{min}$	
	$m_2 = \pm 7\%$	$m_2 = \pm 10\%$
	$\geq 1d$	$\geq 1d$
	$\geq 4d$	$\geq 2d$
	$\geq 2d$	$\geq 2d$
	$\geq 2d$	$\geq 2d$

$m_2 = \pm 5\%$ :  $L_{min} \geq 10d$

IRIS 80

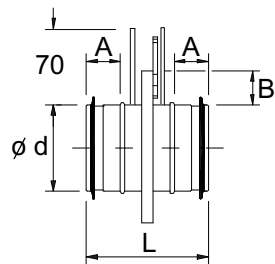
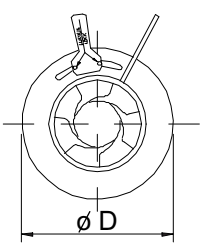

IRIS 100...800

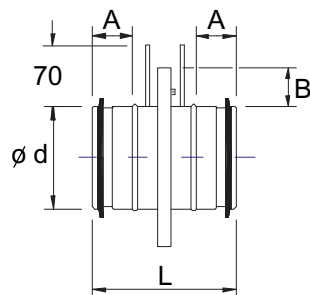
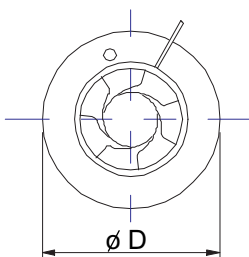

IRIS	$\varnothing d$	$\varnothing D$	L	A	B
80	79	125	120	35	22
100	99	165	110	30	32
125	124	188	110	30	32
150	149	230	210	40	40
160	159	230	110	30	35
200	199	285	110	30	42
250	249	335	135	40	42
315	314	410	135	40	47
400	398	525	190	60	62
500	498	655	170	50	77
630	628	815	170	50	92
800	798	1015	270	100	107

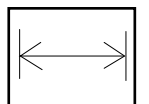

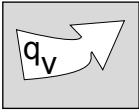

IRIS	k															
	1	1,5	2	2,5	3	3,5	4	4,5	5	5,5	6	6,5	7	7,5	8	
80	6,1	-	4,1	-	3,2	-	2,3	-	1,4	-	0,9	-	0,6	-	-	
100	10,4	7,9	7,5	6,6	6,0	5,2	4,5	3,8	3,4	2,9	2,5	2,1	1,7	1,2	0,9	
125	13,8	10,4	8,8	7,3	6,5	5,5	4,7	4,0	3,5	3,1	2,7	2,2	1,5	-	-	
150	24,1	20,0	16,5	14,9	13,4	12,0	11,0	10,0	8,9	7,9	6,9	6,0	5,2	4,4	3,7	
160	22,1	17,2	14,8	13,4	12,5	11,5	10,7	9,5	8,5	7,5	6,8	5,6	4,9	4,0	3,5	
200	44,2	36,6	30,9	26,9	23,2	20,6	18,2	15,9	14,0	12,3	11,0	9,6	8,4	6,5	5,0	
250	64,4	53,5	45,6	41,8	38,7	34,5	30,7	27,3	24,1	21,4	18,4	15,8	12,8	10,9	8,9	
315	118,0	88,3	70,0	64,5	58,7	53,0	45,1	42,4	37,0	33,3	30,0	25,9	21,8	19,0	15,8	
400	131,0	-	102,0	-	88,3	-	67,3	-	52,7	-	38,5	-	28,4	-	15,5	
500	230,0	-	177,0	-	146,0	-	112,0	-	88,5	-	66,6	-	48,0	-	30,0	
630	451,0	-	297,0	-	238,0	-	169,0	-	127,0	-	91,6	-	62,8	-	35,1	
800	489,0	-	402,0	-	344,0	-	267,0	-	217,0	-	170,0	-	122,0	-	73,7	

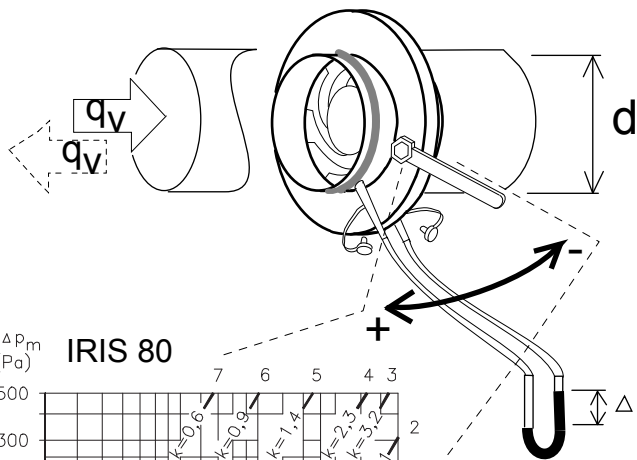

$$q_v = k \sqrt{\Delta p_m}$$

(l/s) (Pa)

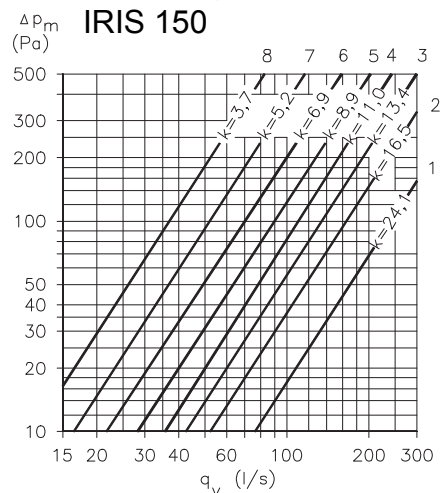
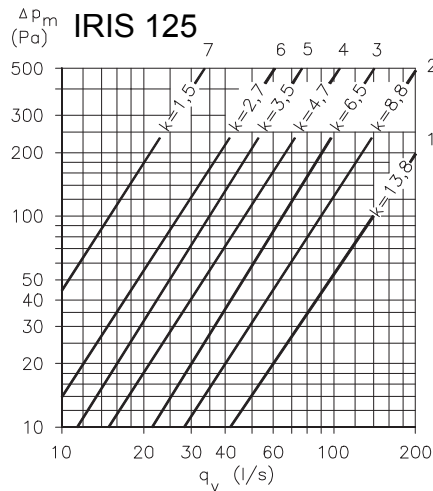
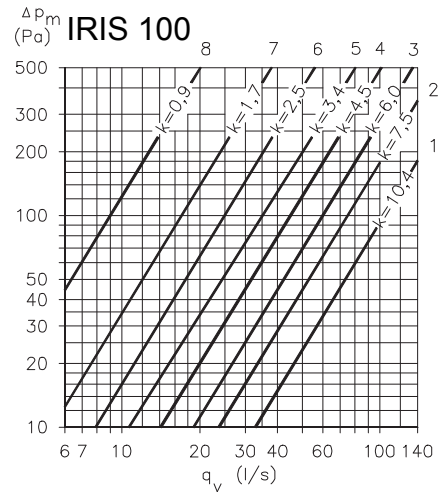
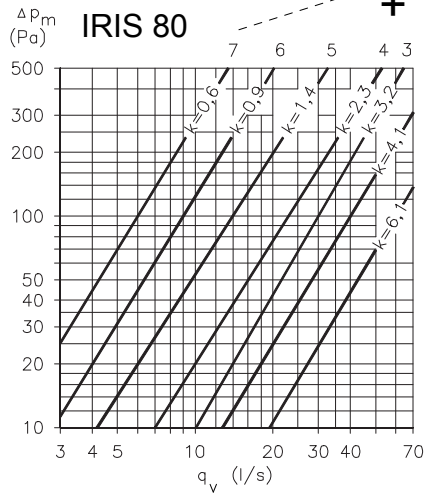

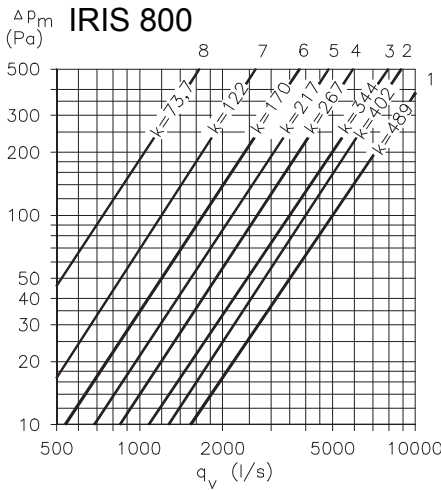
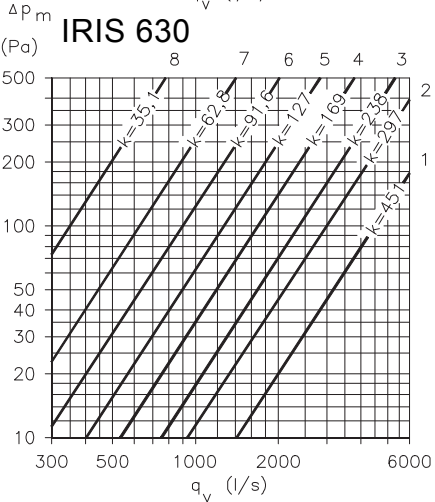
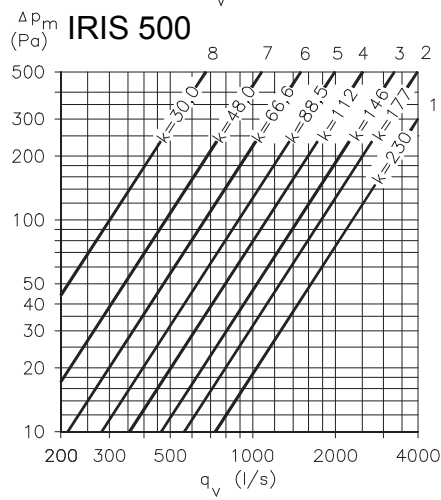
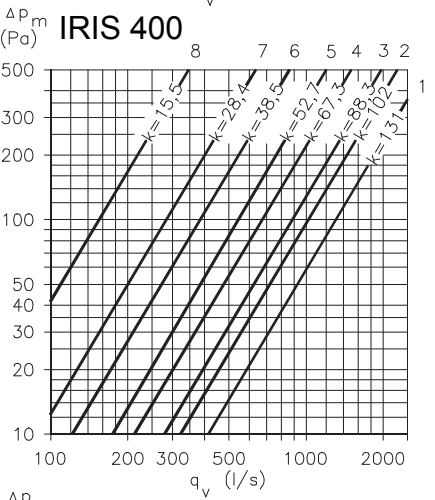
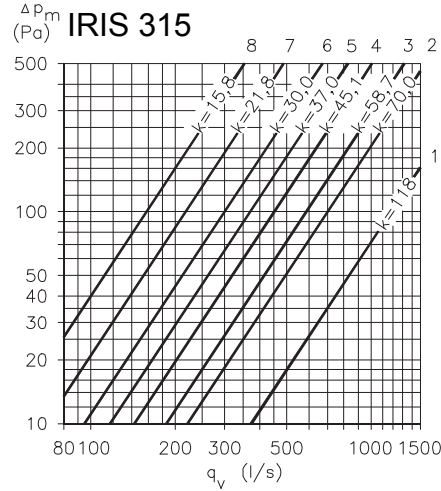
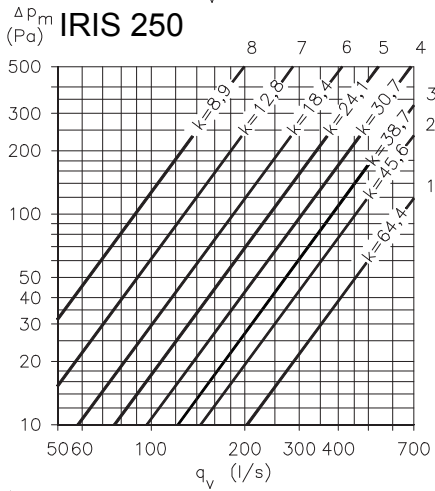
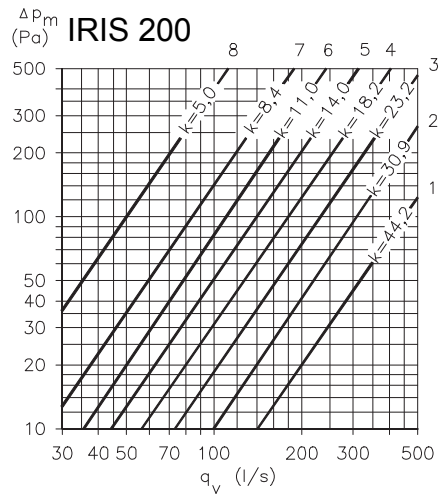
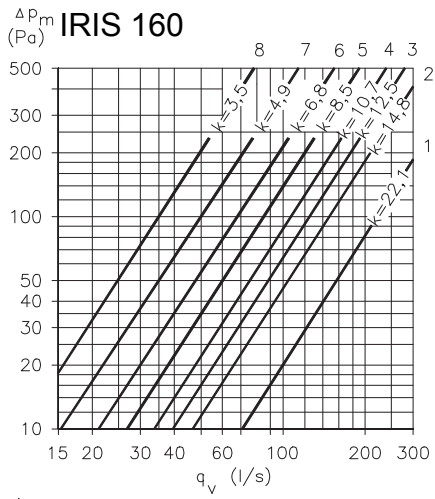



IRIS 80

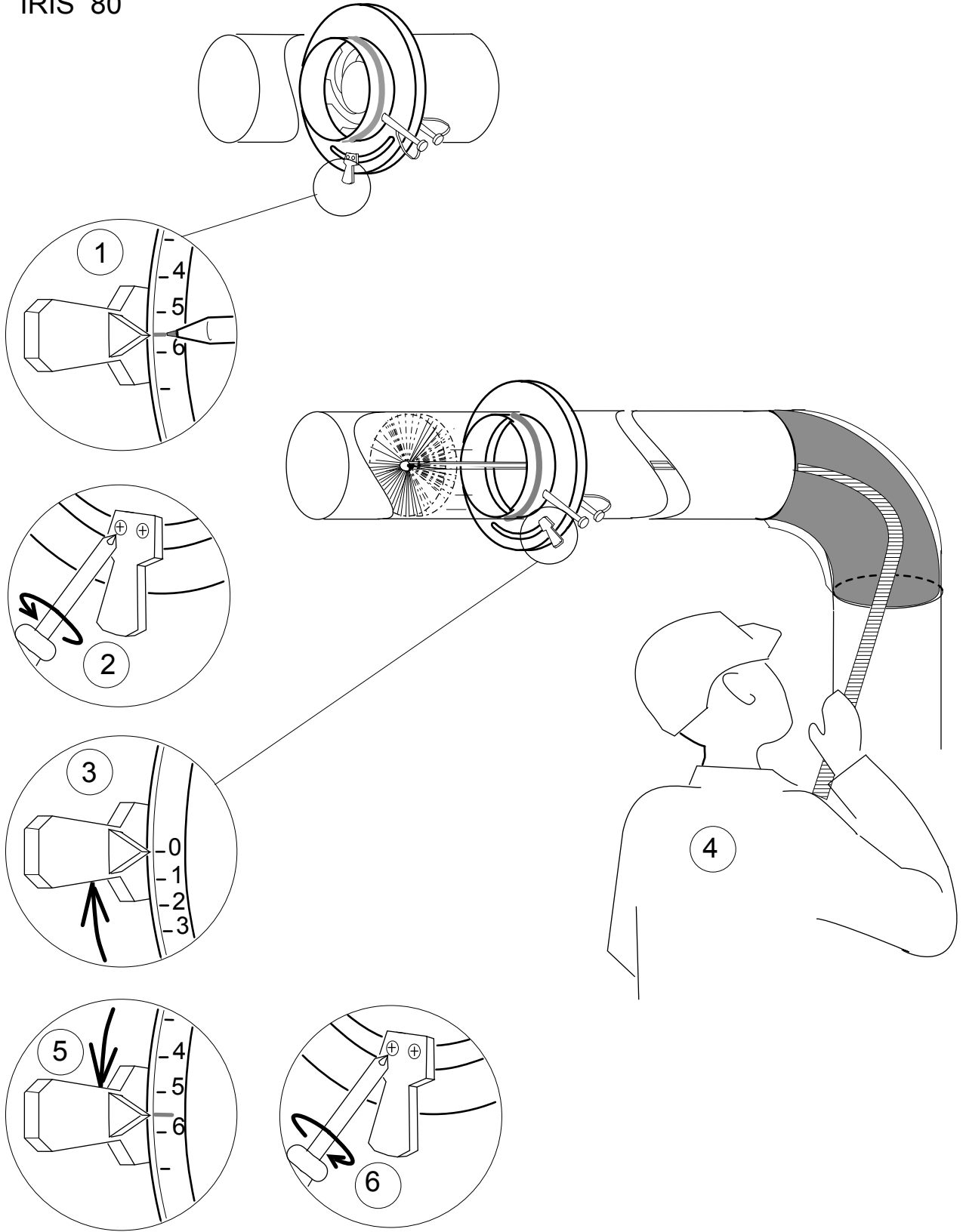



**IRIS 100..315**

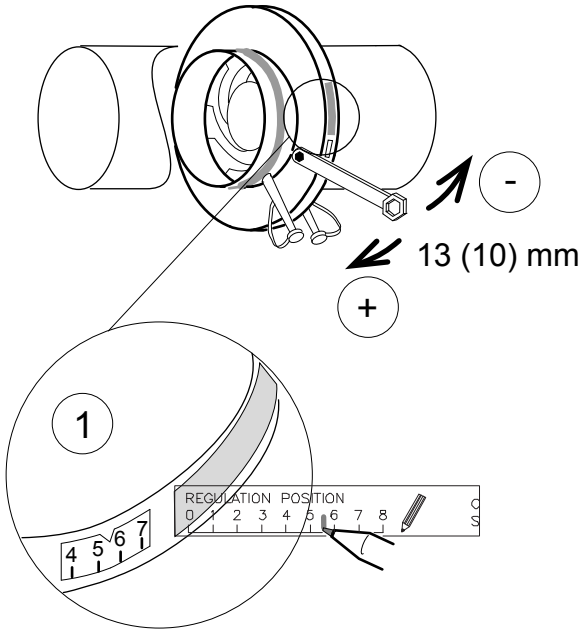

**IRIS 400...800**

